

SYSMAC CS-series MECHATROLINK-II-compatible Motion Control Unit

CS1W-MCH71

CSM_CS1W-MCH71_DS_E_5_1

Improve Equipment Design Efficiency and Shorten Tact Time

- Control Servos for up to 16 axes in a motion network with one Position Control Unit that supports MECHATROLINK-II *.

* MECHATROLINK-II is a registered trademark of the MECHATROLINK Members Association.



CS1W-MCH71

Features

- High-precision motion control with less wiring using MECHATROLINK-II Servo communications with superior concurrency.
- Many synchronization and axis control commands are supported to aid existing synchronized control applications and improve motion control tact time.
- Program control commands (such as branching commands) and various arithmetic operations are supported for maximum motion programming efficiency.

System Configuration

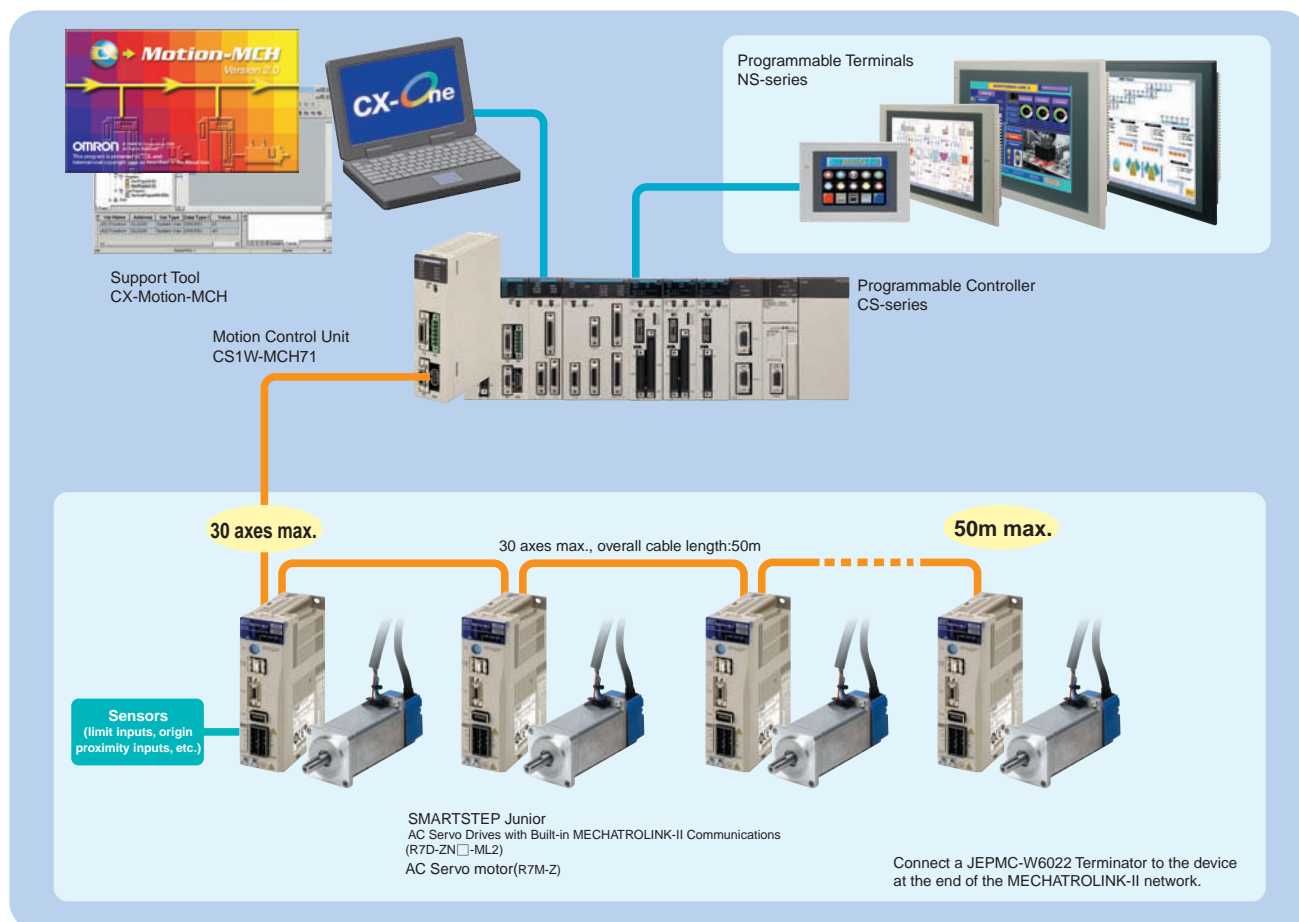

Note: OMNUC G5 series and series cannot be connected with CS1W-MCH71.

Ordering Information

International Standards

- The standards are abbreviated as follows: U: UL, U1: UL(Class I Division 2 Products for Hazardous Locations), C: CSA, UC: cULus, UC1: cULus (Class I Division 2 Products for Hazardous Locations), CU: cUL, N: NK, L: Lloyd, and CE: EC Directives.
- Contact your OMRON representative for further details and applicable conditions for these standards.

CS-series

Unit type	Product Name	Specifications	No. of unit numbers allocated	Current consumption (A)		Model	Standards
				5 V system	26 V system		
CS1 CPU Bus Unit	MECHATROLINK-II-compatible Motion Control Unit 	Control modes: Position, speed, or torque control via MECHSTROLINK-II Control axes: 32 axes max. (30 physical axes, 2 virtual axes) Internal programming language: Special motion control language	1	0.80	–	CS1W-MCH71	UC1, CE

Support Software

Product name	Specifications	Number of licenses	Media	Model	Standards
FA Integrated Tool Package CX-One Ver. 4.□	The CX-One is a comprehensive software package that integrates Support Software for OMRON PLCs and components. CX-One runs on the following OS: Windows XP (Service Pack 3 or higher), Vista, 7 or 8 Note: Except for Windows XP 64-bit version CX-One Ver. 4.□ includes CX-Motion-MCH Ver. 2.□. For details, refer to the CX-One catalog (Cat. No. R134).	1 license *1	DVD *2	CXONE-AL01D-V4	–
CAM Data Creation Tool	Windows 98SE/Me/NT4.0 (Service Pack 6a)/ 2000 (Service Pack 3a or higher), or XP	1 licence	CD	WS02-MOPC2	–

*1. Multi licenses are available for the CX-One (3, 10, 30, or 50 licenses).

*2. The CX-One is also available on CD (CXONE-AL□□C-V4).

MECHATROLINK-related Devices and Cables (Manufactured by Yaskawa Corporation)

Name		OMRON model number	Yaskawa model number
24-VDC I/O Module	Input : 64 Output : 64	FNY-IO2310	JEPMC-IO2310
Counter Module	Reversing Counter 2CH	FNY-PL2900	JEPMC-PL2900
Pulse Output Module	Pulse Positioning 2CH	FNY-PL2910	JEPMC-PL2910
MECHATROLINK-II Cables (with ring core and USB connector on both ends)	0.5 m	FNY-W6003-A5	JEPMC-W6003-A5
	1.0 m	FNY-W6003-01	JEPMC-W6003-01
	3.0 m	FNY-W6003-03	JEPMC-W6003-03
	5.0 m	FNY-W6003-05	JEPMC-W6003-05
	10.0 m	FNY-W6003-10	JEPMC-W6003-10
	20.0 m	FNY-W6003-20	JEPMC-W6003-20
MECHATROLINK-II Terminating Resistor	Terminating resistance	FNY-W6022	JEPMC-W6022
MECHATROLINK-II Repeater	Communications Repeater	FNY-REP2000	JEPMC-REP2000

Note: MECHATROLINK-related Devices and Cables are manufactured by Yaskawa Corporation, but they can be ordered directly from OMRON using the OMRON model numbers. (Yaskawa-brand products will be delivered even when they are ordered from OMRON.)

Accessories

None

Mountable Racks

Model	CS1 system			CS1D system	
	CPU Rack	Expansion Backplane	Long-distance Expansion Racks	CPU Rack	Expansion Backplane
CS1W-MCH71	16 Units max. Per CPU Unit (9 Units per CPU Rack 10 Units per Expansion Backplane)			16 Units max. Per CPU Unit (9 Units per CPU Rack 10 Units per Expansion Backplane)	

Specifications

General Specifications

Item	Specifications
Model	CS1W-MCH71
Power supply voltage	5 VDC (from Backplane)
	24 VDC (from external power supply)
Voltage fluctuation tolerance	4.75 to 5.25 VDC (from Backplane)
	21.6 to 26.4 VDC (from external power supply)
Internal current consumption	5 VDC 0.8 A max.
Weight (Connectors excluded)	300 g max.
Safety standards	UL, CSA, C-TICK, and EC Directives.
Dimensions (mm)	130 (H) × 35 (W) × 100.5 (D) (single)
Altitude	At 2,000 m elevation or lower.

Specifications other than those shown above conform to the general specifications for the SYSMAC CS series.

Functions and Performance Specifications

Item	Specifications	
Applicable PLC	CS-series PLCs with CPU Units with lot number 030418 or later	
Type of Unit	CPU Bus Unit	
Mounting	CPU unit or expansion rack	
Number of Units	One slot	
Method for data transfer with CPU Unit	CIO Area for CPU Bus Unit	Occupies the area for 1 unit (25 words) For units and tasks: 11 to 25 words (Depending on the number of motion tasks)
	DM Area for CPU Bus Unit	Occupies the area for 1 unit (100 words) For units and tasks: 32 to 74 words (Depending on the number of motion tasks)
	Custom Bit Area	For axes: 0-64 words (Depending on the greatest number of the axis used)
	Custom Data Area	For axes: 0-128 words (Depending on the greatest number of the axis used)
	Custom Data Area	For General I/O: 0-1280 words (Depending on setting)
Compatible Devices	<ul style="list-style-type: none"> • OMRON SMARTSTEP Junior Servo Drives (Built-in MECHATROLINK-II communications) • Various I/O units (YASKAWA) Up to 30 nodes * When MECHATROLINK-II devices are connected up to 16 nodes (within 30 m) or 15 nodes (within 50m), a repeater unit is not required. A repeater unit is required to connect MECHATROLINK-II devices more than the cases described above.	
Built-in program language	Dedicated motion control language	
Control	Control method	MECHATROLINK-II <ul style="list-style-type: none"> • Position commands, Speed commands, Torque commands
	Number of controlled axes	32 axes max. Physical axes/Virtual axes: 30 axes max. (Either can be selected for each axis) Dedicated for virtual axes: 2 axes
Operating modes	RUN mode, CPU mode, Tool mode/System (Depending on the tool)	
Automatic/Manual Mode	Automatic mode: Executing built-in programs of MC Unit controls motion. Manual mode: Executing commands from CPU Unit (PC interface area) controls motion. Note: The Automatic or Manual Mode is set according to the PC Interface area of the CPU Unit.	
Control unit	Minimum setting unit	1, 0.1, 0.01, 0.001, 0.0001
	Units	mm, inch, deg, pulse
Maximum position command value	-2147483647 to 2147483647 pulses (signed 32-bit) Mode for unlimited axes feeding is possible. Example: With 16-bit encoder (65536 pulse/rev), Minimum setting unit: 0.001 mm, 10 mm/rev, the position command value range will be from -327679999 to 327679999 command units.	
Control operations based on commands from the CPU Unit	Servo lock/unlock	Executes Servo driver lock or unlock
	Jogging	Executes continuous feeding independently for each axis, by means of speed set in system parameter x override.
	STEP operation	Feeds a specified distance for a specified axis.
	Origin search	Defines the machines origin according to the search method set in the system parameters.
	Forced origin	Forcibly sets the present position to 0 to establish it as the origin.
	Absolute origin setting	Sets the origin when an absolute encoder is used. Offset value: Signed 32-bit (pulses)
	Error counter reset	Forcibly resets the error counter to 0.
	Present position pre-set	Sets the present position to a user-specified value.
	Machine lock	Prohibits the output of motion commands to the axes.
	Single block	Executes the motion program one block at a time.
Auto/manual change	Switches between auto mode and manual mode.	

Item		Specifications
Control Operations according to motion program	Positioning (PTP)	Executes positioning independently for each axis at the speed set in the system parameters. Simultaneous specification: 8 axes max. /block Simultaneous execution: 32 blocks max. /unit
	Linear interpolation	Executes linear interpolation for up to 8 axes simultaneously at the specified interpolation speed. Simultaneous specification: 8 axes max. /block Simultaneous execution: 32 blocks max. /system
	Circular interpolation	Executes clockwise or counterclockwise circular interpolation for two axes at their specified interpolation speed. Simultaneous specification: 2 or 3 axes/block Simultaneous execution: 16 blocks max. /system
	Origin search	Defines the machine origin according to the search method set in the system parameters. An offset can be specified for the position after the origin search. The absolute encoder can also execute origin search.
	Interrupt feeding	By means of inputs to the servo driver, moves a specified axis for a specified travel distance to perform positioning.
	Time-specified Positioning	Executes positioning with time specified.
	Traverse function	Performs winding operation (traverse control) with two specified axes.
	Electronic Cam, Single Axis	Execute cam operation according to the specified cam table data with reference to elapse of time.
	Synchronous Electronic cam	Executes cam operation according to the specified cam table data with reference to the position of the specified axis.
	Link operation	Executes link operation according to set conditions with reference to the position of the specified axis.
	Electronic Shaft	Executes synchronous operation at a speed calculated with the speed of the specified axis and gear ratio.
	Trailing synchronous operation	Executes trailing + synchronous operations with reference to the position of the specified axis.
	Speed command	Outputs speed commands to the specified axis.
Torque command	Outputs torque commands to the specified axis.	
Acceleration/deceleration curve		Trapezoidal or S-shape
Acceleration/deceleration time	Acceleration/deceleration time	60000 ms max.
	S-shape time constant	30000 ms max.
External I/O	For high-speed servo communication bus	One port for MECHATROLINK-II
	Servo encoder	Incremental rotary encoder Absolute rotary encoder (Unlimited length ABS supported with some conditions)
	I/O	Deceleration stop input (or servo-OFF stop): 1 pt General input: 2 pts General output: 2 pts
	External power supply for I/O	24 V
Feed rate	Rapid feed rate	1 to 2147483647 [Command unit/min]
	Interpolation feed rate	1 to 2147483647 [Command unit/min]
	Override	Changes the operation speed by applying a given factor to the speed specified by the system parameters or the motion program. 0.00 to 327.67% (Setting unit: 0.01%, can be specified for each axis or task)
	Internal override (supported for unit version 3.1 and later)	The feed rate of the following commands can be set by the motion program. Command Rate to which override is applied MOVE Rapid feed rate DATUM Origin return feed rate MOVEI Rapid feed rate, external positioning rate MOVET Rapid feed rate The actual feed rate is calculated using the following formula. Actual feed rate = Axis feed rate × (Axis override + Internal override)
Axis control	Backlash compensation	Compensates mechanical backlash (the mechanical play between driving and driven axes) with a value registered in advance. This function uses a parameter in the servo driver.
	In-position	This function is used whether a positioning is completed or not. This function uses a parameter in the servo driver.
	Position loop gain	This is the position loop gain of the servo driver. This function uses a parameter in the servo driver.
	Feed forward gain	The command values created in the MC Unit are multiplied by this feed forward gain. This function uses a parameter in the Servo Driver.

Item		Specifications
Program	Number of tasks	Motion task: 8 tasks max.
	Parallel branching in task	Motion task: 8 branches max.
	Number of programs	256 programs max. /unit The program Nos. used for programs are from 0000 to 0999.
	Program numbers	0000 to 0499:Main programs for motion tasks 0500 to 0999:Sub-programs for motion tasks
	Program capacity	2 Mbytes 8000 blocks max. /unit by motion program conversion.
	Number of blocks	800 blocks/program
	Position data capacity	10240 points/unit
	Sub-program nesting	5 levels max.
	Start	Starts program operation from program (of another task)
	Start mode	Motion task: Initial, continue, next
	Deceleration stop	Motion task: Executes deceleration stop regardless of block
	Block stop	Motion task: Executes deceleration stop at the end of the block currently being executed.
	Single-block mode	Motion task: the program is executed one block at a time.
Breakpoints (supported for unit version 3.0 and later.)	Breakpoints can be set for any block using the Support Tool. When a breakpoint is set for a block, program execution will stop after that block has been executed.	
Saving program data	MC Unit	Flash memory backup
Zones (supported for unit version 3.0 and later.)		The zone bit turns ON when any variable (including feedback present position, feedback speed, etc.) is within the set range, and OFF when outside of the set range. A maximum of 32 zones can be set.
Data tracing (supported for unit version 3.0 and later.)		A maximum of two groups can be simultaneously traced, with 1 to 16 data items in each group. Note: The items that can be traced are bits and data. These are each handled as a single item. The number of data samples that can be collected is 2,048 samples when 16 items are set for tracing to 32,768 when only 1 item is set for tracing.
Self-diagnostic function		Watchdog, FLASH-ROM check, RAM check, etc.
Error detection function		Deceleration stop input, unit number error, CPU Unit error, software limit over errors, etc.
Error log function		The error log is to be read from the CPU Unit by means of the IORD instructions as needed.
Alarm reset		Alarm reset
Program and CAM data read protection (supported for unit version 3.1 and later)		Third party access to program and CAM data can be restricted using the CX-Motion-MCH version 2.1 read protection function (password setting).

Functions

Electronic Shaft (Electronic Gear) (CONNECT)

This function synchronizes with the main axis at the specified gear ratio. It allows for reductions in mechanical functions and labor requirements for machinery maintenance.

Electronic Cam (CAM, CAMBOX)

An independent electronic cam can be positioned according to execution times specified in the cam data, and a synchronized electronic cam can be operated according to a cam table in synchronization with a specified main axis. A total of 16,000 points for all Units combined can be included for the cam data, and 32 cam tables can be set, enabling complex operations.

Virtual Axes

Any axis can be set as an axis performing an ideal movement. Setting it as the main axis for synchronized control simplifies design and debugging of programs and adjustment of synchronized operations. Also, when slippage occurs in motor operation and workpiece operation, the amount of compensation (for the amount of slippage) can be set as the target value for the virtual axis, and the compensation operation can be easily executed by means of the add axis travel function.

Add Axis Travel (ADDAX, ADDAXR)

This function adds the operation of a superimposed axis to a specified axis, making it easy to perform compensation in feeder and synchronization operations.

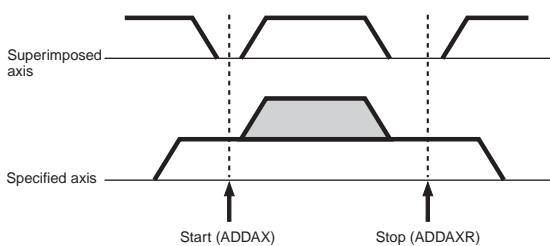

Follow-up Synchronization (SYNC, SYNCR)

From standby status, this function starts follow-up operation when the marker sensor turns ON and executes follow-up synchronization with the main axis. This is ideal for applications that process workpieces without stopping the line.

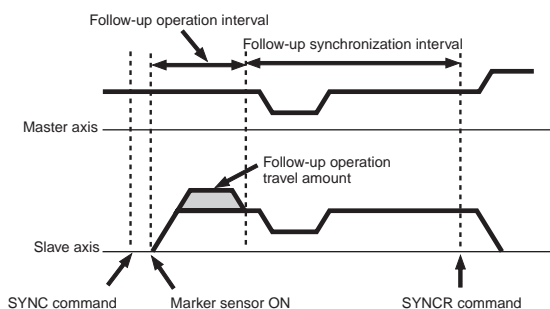

Electronic Links (SYNC)

This function enables the specified synchronized operation with acceleration at the start of synchronization, a ratio during synchronization, and deceleration at the end of synchronization. These specifications are specific for the actual application operation, enabling easy achievement of various types of synchronization operations.

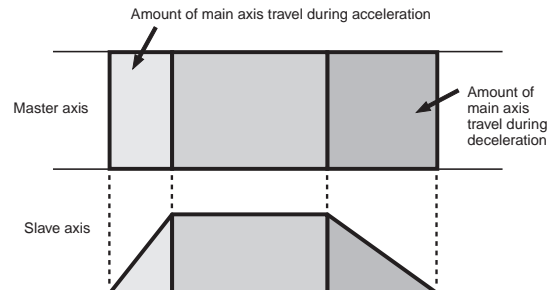

Other Operations

Various applications are made possible by means of a wide range of commands, such as MOVE TIME (MOVET), CHANGE TARGET (MOVEMODI), LATCH (LATCH: With hardware latch and window functions), TRAVERSE (MOVETRAV), TORQUE (TORQUE, TORQUER), SPEED (SPEED, SPEEDR).

Commands

Classification	Name	Command	Function
Axis movement	MOVE, LINEAR INTERPOLATION, CIRCULAR INTERPOLATION	MOVE, MOVEL, MOVEC	Moves axes individually, or using linear or circular interpolation.
	ORIGIN SEARCH	DATUM	Finds the machine origin according to input signals.
	INTERRUPT INCHING	MOVEI	Changes the position by inching according to input signals.
	MOVE TIME	MOVET	Positions according to a specified time.
	TRAVERSE	MOVETRAV	Executes a winding operation.
	INDEPENDENT ELECTRONIC CAM	CAM	Executes cam operations according to a table.
Starting and stopping axis operations	LINK	MOVELINK	Synchronizes with the main axis with acceleration and deceleration.
	SYNCHRONIZED ELECTRONIC CAM	CAMBOX	Executes a cam operation according to a table and main axis.
	ELECTRONIC SHAFT	CONNECT	Synchronizes at fixed rate to main axis.
	FOLLOW-UP SYNCHRONIZATION	SYNC	Follows and synchronizes with the main axis.
	STOP SYNCHRONIZATION	SYNCR	Stops MOVELINK, CAMBOX, CONNECT, and SYNC.
	ADD AXIS TRAVEL	ADDAX, ADDAXR	Starts and stops the accumulation of travel amounts between axes.
	START SPEED, END SPEED	SPEED, SPEEDR	Outputs and stops a speed reference.
	START TORQUE, END TORQUE	TORQUE, TORQUER	Outputs and stops a torque reference.
Settings	CHANGE TARGET	MOVEMODI	Changes the target position for the axis that is travelling.
	ABSOLUTE SPECIFICATION, INCREMENTAL SPECIFICATION	ABL, INC	Handles coordinates as absolute or incremental values.
	CHANGE PARAMETER	PARAM	Changes parameter values at one time.
	PASS MODE	PASSMODE	Specifies operations with interpolation blocks connected.
	STOP MODE	STOPMODE	Waits for the interpolation block to be in position.
	SELECT MACHINE COORDINATE SYSTEM, SELECT WORKPIECE COORDINATE SYSTEM	ORIGIN, WORK	Selects either the machine coordinate system or the workpiece coordinate system.
	CHANGE WORKPIECE ORIGIN OFFSET	OFFPOS	Changes the offset of the workpiece coordinate system.
	LATCH	LATCH	Latches the present position.
Controls	IGNORE SINGLE BLOCK	NSTOP	Ignores single block mode.
	PROGRAM START, PROGRAM END	PROG, END	Marks the beginning or end of a program.
	SUBPROGRAM CALL, SUBPROGRAM END	GOSUB, RETURN	Calls a subprogram or ends a subprogram and returns to the source of the call.
	DWELL, WAIT	DWELL, WAIT	Waits for a specified length of time or for a specified condition to be met and then executes the next block.
	OPTIONAL END	STOPOP	Stops the block being executed when a specified condition is met.
	Conditional Branching	IF, ELS, ENDIF	Branches according to conditions.
	WHILE Repeat Commands	WHILE, WEND	Repeats until any specified condition is met.
	FOR Repeat Commands	FOR, NEXT	Repeats until specified count (constant, variable, or immediate) is met.
	Parallel Execution	PARALLEL, JOINT, JWAIT	Executes in parallel for the specified interval.
	Selected Execution	SWITCH, CASE, BREAK, DEFAULT, SEND	Switches and executes the specified section according to conditions.
Simple operations	NO OPERATION SINGLE, NO OPERATION MULTIPLE	NOPS, NOPM	Nothing is executed. (Single or multiple execution command)
	SUBSTITUTION	=	Substitutes values for variables.
	Arithmetic Operations	+, -, *, /, ^	Performs addition, subtraction, multiplication, division, and power operations.
Logical operations	REMAINDER	%	Finds the remainder in division operations.
	OR/XOR/AND/NOT	, ., &, !	Performs logical OR, XOR, AND, and NOT operations.
Functions	ABSOLUTE	ABS	Finds the absolute value.
	SINE, COSINE, ASINE, ACOSINE	SIN, COS, ASIN, ACOS	Finds the sine, cosine, arcsine, or arccosine.
	TANGENT, ATANGENT	TAN, ATAN	Finds the tangent or arctangent.
	SQUARE ROOT, EXPONENT, LOGARITHM	SQR, EXP, LOG	Finds the square root, exponent, or logarithm.
	FRACTION	FRAC	Finds the decimal portion.
	SIGN	SGN	1 if greater than 0, and -1 if negative.
Bit operations	BIT ON, BIT OFF	SET, RESET	Turns a specified bit ON or OFF.
	RIGHT SHIFT, LEFT SHIFT	SFTR, SFTL	Shifts right or left for the specified number of bits.
Data operations	BCD → BIN/BIN → BCD	BIN, BCD	Converts from BCD to binary, or from binary to BCD.
	BLOCK TRANSFER, BLOCK CLEAR	XFER, CLEAR	Transfers or clears a block of data.

External Interface

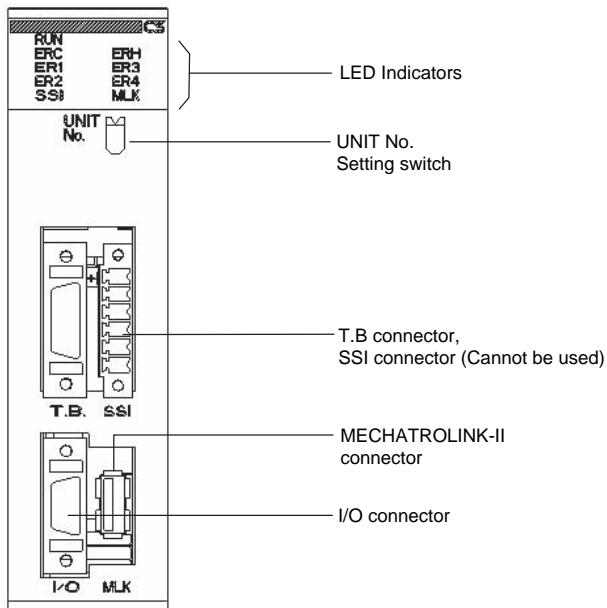

LED Indicators

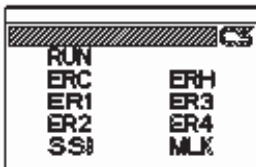

Name	Color	Status	Content
RUN (RUN)	Green	Lit	Motion Control Unit is operating normally.
		Not lit	Not recognized by PLC, or MC Unit is broken.
ERC (MC Unit Error)	Red	Lit	An error has occurred in the MC Unit.
		Not lit	MC Unit is operating normally.
ERH (CPU Unit Error)	Red	Lit	An error has occurred in the CPU Unit.
		Not lit	CPU Unit is operating normally.
ER1 * (Internal error status)	Yellow	Lit	An internal error has occurred.
		Not lit	MC Unit is operating normally.
ER2 * (Internal error status)	Yellow	Lit	An internal error has occurred.
		Not lit	MC Unit is operating normally.
ER3 * (Internal error status)	Yellow	Lit	An internal error has occurred.
		Not lit	MC Unit is operating normally.
ER4 * (Internal error status)	Yellow	Lit	An internal error has occurred.
		Not lit	MC Unit is operating normally.
SSI	Yellow	Lit	Not used.
		Not lit	Not used.
MLK (MECHATROLINK-II)	Yellow	Lit	MLK is operating normally.
		Not lit	An error has occurred in the MLK.

* When the ERC or ERH indicator is lit, these four indicators show the internal error status.

Functions Supported by CS1W-MCH71 Units Version 2.0 or Later

Unit version		Pre-Ver. 2.0	Unit Ver. 2.0	Unit Ver. 3.0	Unit Ver. 3.1
Internal system software version		1.00 to 1.04	1.05	1.08	1.09
MC Unit model		CS1W-MCH71			
Functions	Jogging	–	Supported	Supported	Supported
	Communications levels	–	Supported	Supported	Supported
	Communications cycle and unit cycle	–	Supported	Supported	Supported
	LATCH command processing time	–	Supported	Supported	Supported
	Latch status refresh time	–	Supported	Supported	Supported
	Using interpolation commands during pass operation	–	Supported	Supported	Supported
	Acceleration/deceleration time during pass operation	–	Supported	Supported	Supported
	Deceleration time during pass operation	–	Supported	Supported	Supported
	Torque to position control switching	–	Supported	Supported	Supported
	Expanded allocations in Custom I/O Area	–	–	Supported *1	Supported *1
	Digital input values changed to improve noise immunity	–	–	Supported	Supported
	Faster unit cycle and communications cycle times	–	–	Supported	Supported
	Signed master axis MOVELINK command	–	–	Supported	Supported
	Indirect writing of position data	–	–	Supported	Supported
	Status of program start bit	–	–	Supported	Supported
	Re-execution of WAIT command	–	–	Supported	Supported
	Main power status	–	–	Supported	Supported
	Servo Driver status	–	–	Supported	Supported
	Increased precision of CAMBOX command	–	–	Supported	Supported
	Data tracing	–	–	Supported *1	Supported *1
	Debugging	–	–	Supported *1	Supported *1
	Zones	–	–	Supported *1	Supported *1
	Setting the number of parallel branches for each task	–	–	Supported *1	Supported *1
	Present position preset to establish origin	–	–	Supported *1	Supported *1
	Servo OFF for deceleration stop signal	–	–	Supported *1	Supported *1
Improved restarting after restoration	–	–	–	Supported	
Expanded bank switching for interpolation acceleration/deceleration times	–	–	–	Supported	
Internal overrides	–	–	–	Supported	
Connecting to SMARTSTEP Junior Servo Drivers	–	–	–	Supported *2	
Improved backup and restore functions	–	–	–	Supported *2	
Program and CAM data read protection	–	–	–	Supported *2	
Applicable Support Tool		CX-Motion-MCH • Functions for unit version 3.0 indicated by “*1” can be used with CX-Motion-MCH version 2.0 or higher. • Functions for unit version 3.1 indicated by “*2” can be used with CX-Motion-MCH version 2.1 or higher.			

CS1W-MCH71 Unit Versions and Manufacturing Dates/Lot Numbers

Classification	Type	Model	Manufacturing dates			
			From early June 2004	From July 2004	From March 2007	From early July 2007
CPU Bus Unit	MC Unit	CS1W-MCH71	Pre-Ver. 2.0	Unit version 2.0 (Lot No.: 040715 and later)	Unit version 3.0 (Lot No.: 070313 and later)	Unit version 3.1 (Lot No.: 070615 and later)

Dimensions

CS1W-MCH71

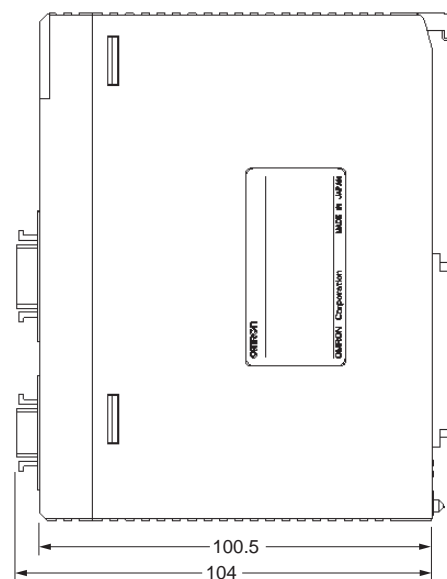
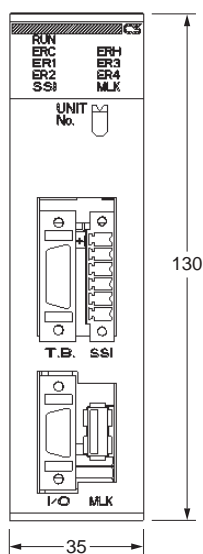

Related Manual

English Cat. No.	Japanese Cat. No.	Model	Name
W435	SBCE-327	CS1W-MCH71/CJ1W-MCH71	CS1W-MCH71/CJ1W-MCH71 CS/CJ-series MECHATROLINK-II-compatible Motion Control Unit User's Manual
W448	SBCE-336	CXONE-AL□□C-V□/ CXONE-AL□□D-V□	CX-Motion-NCH Operation Manual
—	SBCE-046	CS1W-MCH71/CJ1W-MCH71	CS1W-MCH71/CJ1W-MCH71 Motion Control Unit (ONNUC W-series) Technical Guide

Terms and Conditions Agreement

Read and understand this catalog.

Please read and understand this catalog before purchasing the products. Please consult your OMRON representative if you have any questions or comments.

Warranties.

(a) Exclusive Warranty. Omron's exclusive warranty is that the Products will be free from defects in materials and workmanship for a period of twelve months from the date of sale by Omron (or such other period expressed in writing by Omron). Omron disclaims all other warranties, express or implied.

(b) Limitations. OMRON MAKES NO WARRANTY OR REPRESENTATION, EXPRESS OR IMPLIED, ABOUT NON-INFRINGEMENT, MERCHANTABILITY OR FITNESS FOR A PARTICULAR PURPOSE OF THE PRODUCTS. BUYER ACKNOWLEDGES THAT IT ALONE HAS DETERMINED THAT THE PRODUCTS WILL SUITABLY MEET THE REQUIREMENTS OF THEIR INTENDED USE.

Omron further disclaims all warranties and responsibility of any type for claims or expenses based on infringement by the Products or otherwise of any intellectual property right. (c) Buyer Remedy. Omron's sole obligation hereunder shall be, at Omron's election, to (i) replace (in the form originally shipped with Buyer responsible for labor charges for removal or replacement thereof) the non-complying Product, (ii) repair the non-complying Product, or (iii) repay or credit Buyer an amount equal to the purchase price of the non-complying Product; provided that in no event shall Omron be responsible for warranty, repair, indemnity or any other claims or expenses regarding the Products unless Omron's analysis confirms that the Products were properly handled, stored, installed and maintained and not subject to contamination, abuse, misuse or inappropriate modification. Return of any Products by Buyer must be approved in writing by Omron before shipment. Omron Companies shall not be liable for the suitability or unsuitability or the results from the use of Products in combination with any electrical or electronic components, circuits, system assemblies or any other materials or substances or environments. Any advice, recommendations or information given orally or in writing, are not to be construed as an amendment or addition to the above warranty.

See <http://www.omron.com/global/> or contact your Omron representative for published information.

Limitation on Liability; Etc.

OMRON COMPANIES SHALL NOT BE LIABLE FOR SPECIAL, INDIRECT, INCIDENTAL, OR CONSEQUENTIAL DAMAGES, LOSS OF PROFITS OR PRODUCTION OR COMMERCIAL LOSS IN ANY WAY CONNECTED WITH THE PRODUCTS, WHETHER SUCH CLAIM IS BASED IN CONTRACT, WARRANTY, NEGLIGENCE OR STRICT LIABILITY.

Further, in no event shall liability of Omron Companies exceed the individual price of the Product on which liability is asserted.

Suitability of Use.

Omron Companies shall not be responsible for conformity with any standards, codes or regulations which apply to the combination of the Product in the Buyer's application or use of the Product. At Buyer's request, Omron will provide applicable third party certification documents identifying ratings and limitations of use which apply to the Product. This information by itself is not sufficient for a complete determination of the suitability of the Product in combination with the end product, machine, system, or other application or use. Buyer shall be solely responsible for determining appropriateness of the particular Product with respect to Buyer's application, product or system. Buyer shall take application responsibility in all cases.

NEVER USE THE PRODUCT FOR AN APPLICATION INVOLVING SERIOUS RISK TO LIFE OR PROPERTY OR IN LARGE QUANTITIES WITHOUT ENSURING THAT THE SYSTEM AS A WHOLE HAS BEEN DESIGNED TO ADDRESS THE RISKS, AND THAT THE OMRON PRODUCT(S) IS PROPERLY RATED AND INSTALLED FOR THE INTENDED USE WITHIN THE OVERALL EQUIPMENT OR SYSTEM.

Programmable Products.

Omron Companies shall not be responsible for the user's programming of a programmable Product, or any consequence thereof.

Performance Data.

Data presented in Omron Company websites, catalogs and other materials is provided as a guide for the user in determining suitability and does not constitute a warranty. It may represent the result of Omron's test conditions, and the user must correlate it to actual application requirements. Actual performance is subject to the Omron's Warranty and Limitations of Liability.

Change in Specifications.

Product specifications and accessories may be changed at any time based on improvements and other reasons. It is our practice to change part numbers when published ratings or features are changed, or when significant construction changes are made. However, some specifications of the Product may be changed without any notice. When in doubt, special part numbers may be assigned to fix or establish key specifications for your application. Please consult with your Omron's representative at any time to confirm actual specifications of purchased Product.

Errors and Omissions.

Information presented by Omron Companies has been checked and is believed to be accurate; however, no responsibility is assumed for clerical, typographical or proofreading errors or omissions.